

EluTM
WOODWORKING TOOLS BY
BLACK&DECKER

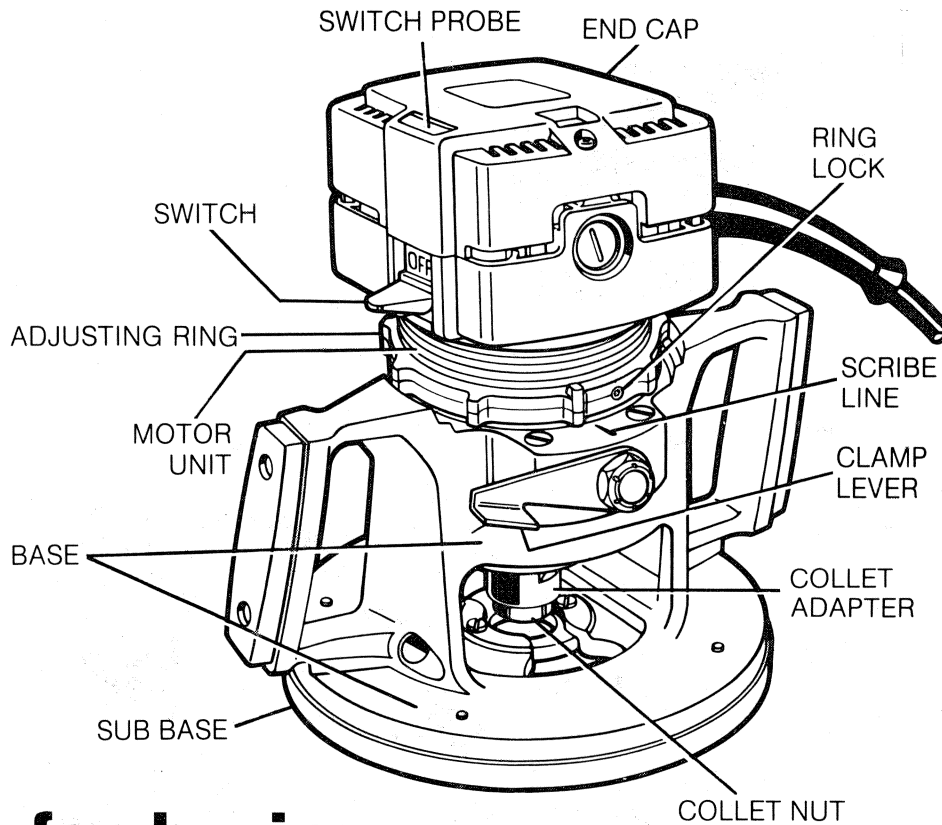

Instruction Manual

3 1/2 H.P. Router
3328



Thanks for buying an Elu Power Tool.

If you already own an Elu Power Tool, you know the pleasures of working with a true professional.

Built with Elu's commitment to quality and value, your new router is designed to deliver years of dependable service.

Plenty of power for the really tough jobs combined with unsurpassed accuracy make your 3328 Router an exceptional value.

With the proper accessories you can rout in all types of hard and softwoods, plastic laminates, compositions and even aluminum.

Fully adjustable depth controls and a depth locking lever make depth settings easy and accurate.

The broad array of accessories listed in this manual will perform just about any routing job you have with ease, speed and precision.

Please take the time to thoroughly read this instruction manual and pay particular attention to the safety rules we've provided for your protection.

Don't forget to send in your owner's registration card.

**THANKS FOR SELECTING
ELU!**



SAFETY INSTRUCTIONS

WARNING: When using Electric Tools, basic safety precautions should always be followed to reduce the risk of fire, electric shock, and personal injury, including the following:

READ ALL INSTRUCTIONS

1. **KEEP WORK AREA CLEAN.** Cluttered areas and benches invite injuries.
2. **CONSIDER WORK AREA ENVIRONMENT.** Don't expose power tools to rain. Don't use power tools in damp or wet locations. Keep work area well lit.
3. **GUARD AGAINST ELECTRIC SHOCK.** Prevent body contact with grounded surfaces. For example: pipes, radiators, ranges, refrigerator enclosures.
4. **KEEP CHILDREN AWAY.** All visitors should be kept away from work area. Do not let visitors contact tool or extension cord.
5. **STORE IDLE TOOLS.** When not in use, tools should be stored in dry, and high or locked-up place—out of reach of children.
6. **DON'T FORCE TOOL.** It will do the job better and safer at the rate for which it was intended.
7. **USE RIGHT TOOL.** Don't force small tool or attachment to do the job of a heavy-duty tool. Don't use tool for purpose not intended, for example, don't use circular saw for cutting tree limbs or logs.
8. **DRESS PROPERLY.** Do not wear loose clothing or jewelry. They can be caught in moving parts. Rubber gloves and nonskid foot wear are recommended when working outdoors. Wear protective hair covering to contain long hair.
9. **USE SAFETY GLASSES.** Also use face or dust mask if cutting operation is dusty.
10. **DON'T ABUSE CORD.** Never carry tool by cord or yank it to disconnect from receptacle. Keep cord from heat, oil, and sharp edges.
11. **SECURE WORK.** Use clamps or a vise to hold work. It's safer than using your hand and it frees both hands to operate tool.
12. **DON'T OVERREACH.** Keep proper footing and balance at all times.
13. **MAINTAIN TOOLS WITH CARE.** Keep tools sharp and clean for better and safe performance. Follow instructions for lubricating and changing accessories. Inspect tool cords periodically and if damaged have repaired by authorized service facility. Inspect extension cords periodically and replace if damaged. Keep handles dry, clean, and free from oil and grease.
14. **DISCONNECT TOOLS.** When not in use, before servicing, and when changing accessories, such as blades, bits, cutters.
15. **REMOVE ADJUSTING KEYS AND WRENCHES.** Form habit of checking to see that keys and adjusting wrenches are removed from tool before turning it on.
16. **AVOID UNINTENTIONAL STARTING.** Don't carry plugged-in tool with finger on switch. Be sure switch is off when plugging in.
17. **OUTDOOR USE EXTENSION CORDS.** When tool is used outdoors, use only extension cords intended for use outdoors and so marked.
18. **STAY ALERT.** Watch what you are doing. Use common sense. Do not operate tool when you are tired.
19. **CHECK DAMAGED PARTS.** Before further use of tool, a guard or other part that is damaged should be carefully checked to determine that it will operate properly and perform its intended function. Check for alignment of moving parts, binding of moving parts, breakage of parts, mounting, and any other conditions that may affect its operation. A guard or other part that is damaged should be properly repaired or replaced by an authorized service center unless otherwise indicated elsewhere in this instruction manual. Have defective switches replaced by authorized service center. Do not use tool if switch does not turn it on and off.
20. **DO NOT OPERATE** portable electric tools near flammable liquids or in gaseous or explosive atmospheres. Motors in these tools normally spark, and the sparks might ignite fumes.
21. **IF THE TOOL DOES NOT OPERATE** when turned on, unplug the tool, allow the tool to rest at room temperature and try again before returning for service.
22. Wear ear protection for extended use.
23. **KEEP AIR SLOTS CLEAN FOR BETTER AND SAFER PERFORMANCE.**

SAVE THESE SAFETY RULES FOR FUTURE USE.

Grounding Instructions

This tool should be grounded while in use to protect the operator from electric shock. The tool is equipped with an Underwriters Laboratory (U.L.) approved three-conductor cord and three-prong grounding type plug to fit the proper grounding type receptacle. The green (or green and yellow) conductor in the cord is the grounding wire. Never connect the green (or green and yellow) wire to a live terminal.

If your unit is for use on less than 150 volts, it has a plug like that shown in Figure A.

If it is for use on 150 to 250 volts, it has a plug like that shown in Figure D.

An adapter, Figures B and C, is available for connecting Figure A plugs to two-prong receptacles. The green-colored rigid ear, lug, etc., must be connected to a permanent ground such as a properly grounded outlet box. No adapter is available for a plug as shown in Figure D. Adapter shown in Figure B & C is Not for Use in Canada.

We recommend that you **NEVER** disassemble the tool or try to do any rewiring in the electrical system. Any repairs should be performed only by B & D Service Centers or other qualified service organizations. Should you make a repair yourself, remember that the green colored wire is the "grounding" wire. Never connect this green wire to a "live" terminal. If you replace the plug on the power cord, be sure to connect the green wire only to the grounding (longest) prong on a 3-prong plug.

SAVE THESE INSTRUCTIONS

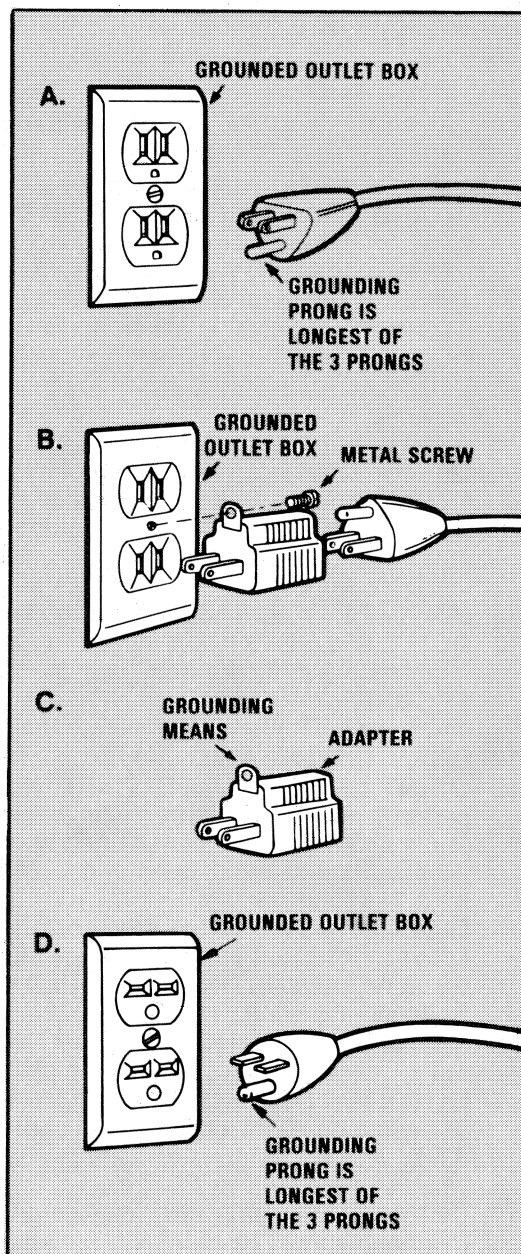

Motor

Your Elu tool is powered by an Elu-built motor. Be sure your power supply agrees with voltage marked on nameplate. Volts 50/60 Hz means Alternating Current only. Volts DC-60 Hz or AC/DC means it will also operate on Alternating Current or Direct Current. Voltage decrease of more than 10% will cause loss of power and overheating.

Clamp Lever

Turn Off And Unplug Router.

In order to lock the position of the router motor unit in the router base, a lever has been provided on the side of the tool, as shown in Figure 1.

To lock the motor unit in place, push the lever all the way down; to release the motor, raise the lever up to about a right angle to the tool. Use this loosened position for making depth adjustments and removing the motor unit from the base. **ALWAYS BE SURE THAT THE CLAMP LEVER IS IN THE LOCKED (DOWN) POSITION WHEN ROUTING.**

The orientation of the lever can be changed if desired by loosening the lock nut that fastens it to the router and rotating the lever to the desired position. Retighten the lock nut.

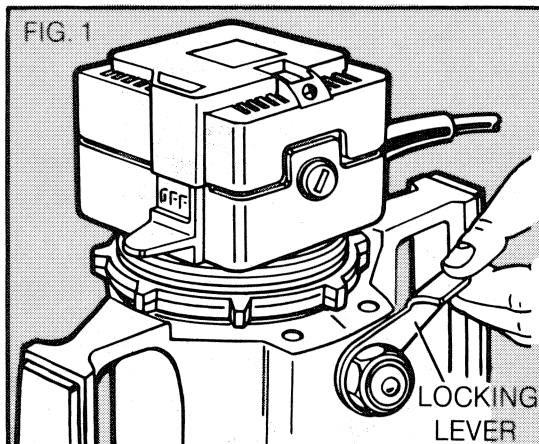

Sub Base

Turn Off And Unplug Router

The sub-base on your router has been specifically designed to permit better visibility than conventional routers but retain the ability to use template guides. The guide adapter, if not needed, can be easily removed for even more visibility. To remove the adapter raise the Clamp Lever and lift the motor assembly out of the router base. This will enable you to reach and remove the two screws in the base which hold the guide adapter in place, as shown in Figure 2.

When you reinstall the motor unit, be sure to align the Guide Screw (Figure 3) with the slot in the router base.

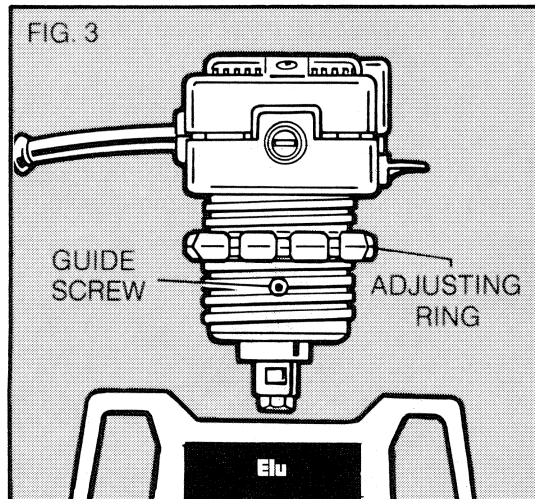
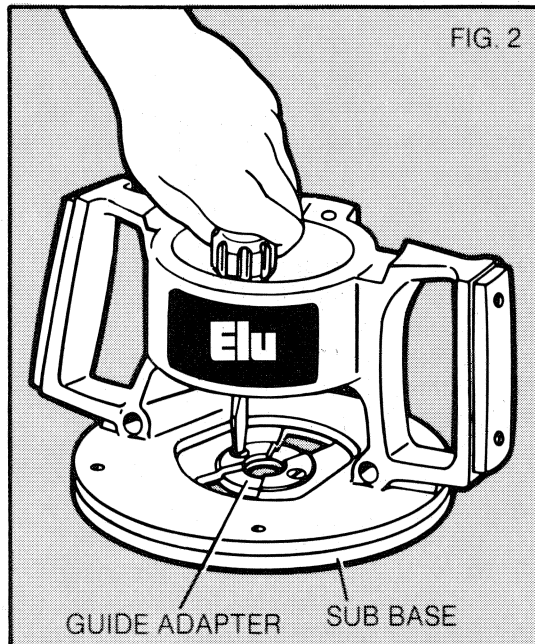

Sub Base Alignment For Template Routing

The guide adapter is aligned with the collet at the time of manufacture, but the two may become misaligned during shipping and handling, particularly if the tool is dropped. To properly align the collet with the guide adapter follow the steps below.

1. Turn Off And Unplug Router.
2. Raise the Clamp Lever and remove the motor unit from the router base.
3. Remove the Guide Screw and the Adjusting Ring shown in Figure 3.

4. Loosen the 4 screws in the Sub Base, as shown in Figure 4.
5. Re-insert the Guide Screw (not the Adjusting Ring) in the motor unit and insert the motor unit into the router base. (Make sure that you align the Guide Screw with the slot in the router base.)
6. Lower the motor unit until the collet adapter extends through the guide adapter, as shown in Figure 5. Adjust the Sub Base until the collet adapter fits through it.
7. Tighten the four screws in the Sub Base and remove the motor unit from the router base.
8. Remove the Guide Screw and re-install the Adjusting Ring.
9. Install the Guide Screw and re-insert the motor unit into the router base. (Be sure to align the guide screw with the slot in the base.)
10. The template guide is now aligned with the collet.

NOTE: When installing the guide screw in the above section remember that it must be tightened firmly so that the head is flush against the side of the motor unit.

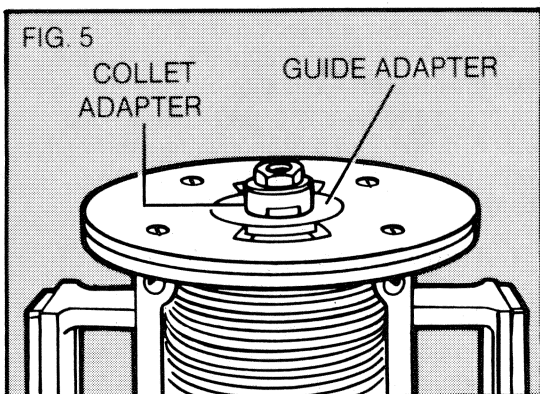
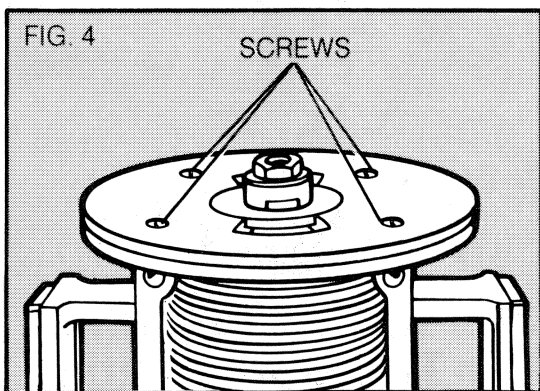

Attaching Bits and Cutters

Turn Off And Unplug Router

Insert the shank of the desired bit or cutter into the collet as far as it will go, then pull it out slightly (about 1/32"). Use the wrenches provided to securely tighten the collet nut. One wrench holds the collet adapter and the other tightens the collet nut.

A special coating has been put on the collet and collet nut to increase the bit holding power. Use only the wrenches provided with your router to tighten the collet nut. Other tools may damage the coating through overtightening.

Depth Adjustment

Turn Off And Unplug Router

Loosen the Clamp Lever by raising it fully. Adjust the depth setting of the router bit by turning the Adjusting Ring shown in Figure 6. To raise the bit away from the work surface, turn the ring clockwise (as viewed from the top of the tool) and to lower the bit into the work, turn it counterclockwise.

Directly over the Clamp Lever pivot point is a line scribed into the aluminum housing, as shown in Figure 6. As the ring is rotated, the raised lugs on the ring will pass over this line. Each time a lug passes the line, the bit is raised or lowered 1/64". Every full revolution of the Adjusting Ring accounts for 1/8" of adjustment either up or down.

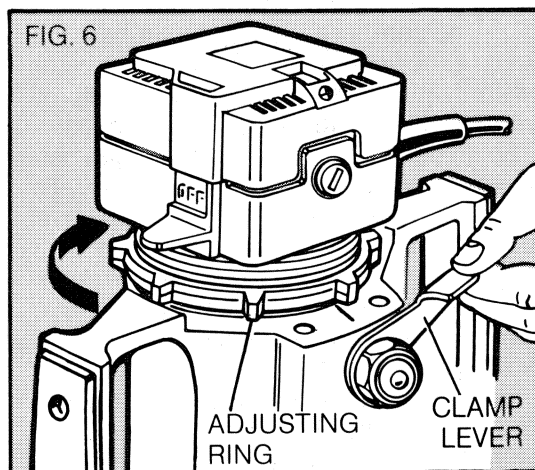

The lugs are consecutively numbered for convenience. For faster adjustments, lift the motor housing slightly and spin the Adjusting Ring.

Duplicating specific depths of cut, such as hinge butt mortises, can be done quickly and accurately by following the steps below.

1. **TURN OFF AND UNPLUG ROUTER.**
2. Lower the router bit until it just touches the workpiece. (Refer to preceding section on "DEPTH ADJUSTMENT")
3. Lock the Clamp Lever.
4. Raise the Adjusting Ring by rotating it counterclockwise until the hinge will just fit between the top edge of the router base and the bottom of the Adjusting Ring, as shown in Figure 7.
5. Remove the hinge and invert the router to prevent the bit from marring the work surface.
6. Unlock the Clamp Lever and allow the base to fall to the new setting. Lock the Clamp Lever in place and the depth is set. The router will now cut to the exact thickness of the hinge.

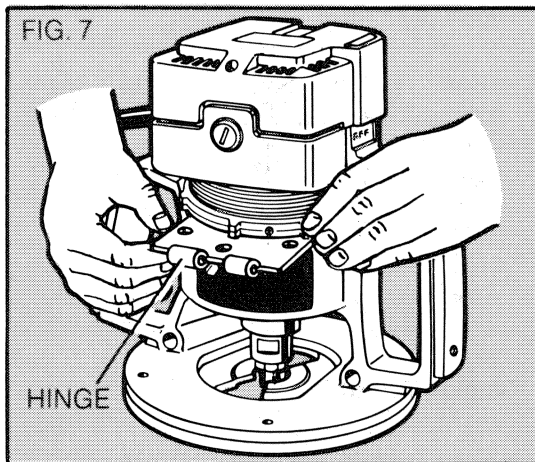

Adjusting Ring Lock

Turn Off And Unplug Router.

To prevent the Adjusting Ring from rotating due to vibration of the router, a nylon set screw has been provided in the ring. When the ring is set as desired, tighten this set screw, shown in Figure 8. Be careful to avoid overtightening which will strip the soft nylon screw. The set screw can be used whenever desired, or never at all.

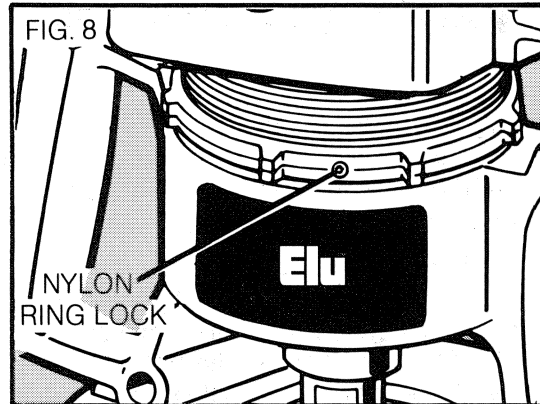

On/Off Switch

The on/off switch is located on the side of the router, just above the hand grip. Figure 9. To turn on the router, raise the on/off switch lever with your thumb while gripping the tool. To turn off the router, pull the switch lever down. When the router is running, you will notice a probe extending from the top of the router. This probe is connected to the on/off switch lever and can be used to turn off the router by pushing it down toward the end cap. This probe also prevents the router from inadvertently being turned on when it is inverted and resting on its end cap. The end cap is designed so that the router can be inverted for temporary storage, when changing the work piece, and while changing router bits. Figure 10.

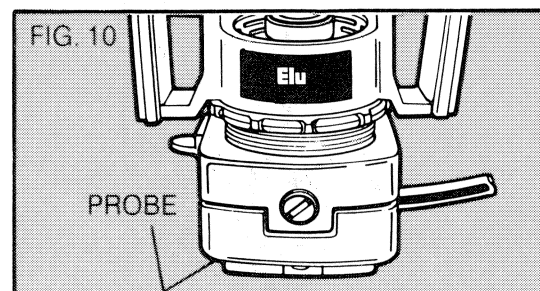
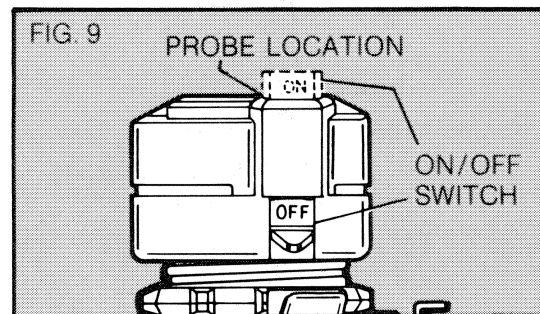

Router Accessories

Select bits from three basic materials:

High-Speed Steel Bits

Made from M-2 steel for fast, clean performance in normal routing of wood and aluminum.

Carbide-Tipped Steel Bits

Produced from selected grades of tungsten carbide which is permanently bonded to an alloy steel body. Excellent for routing laminates, plastics, composition board, and plywood.

Solid Carbide Bits

One-piece construction designed to withstand high torques. Excellent for continuous production routing in mills and cabinet shops.

Cyclone™ Router Bits

Choose from straight bits, grooving bits, decorating bits, laminate and aluminum trimming bits, and slotting cutters—all designed to stay sharp longer, reduce downtime and costs.

Straight Bits

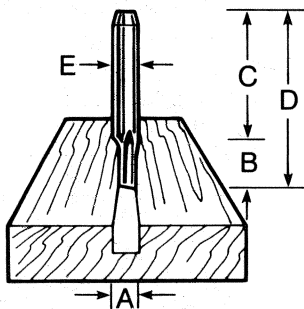

Single Flute

Excellent for roughing and hogging where speed and chip clearance are important.

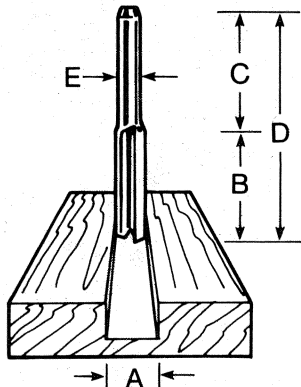

Two Flutes

Balanced cutting with minimum vibration for smoothness and uniformity of cut.

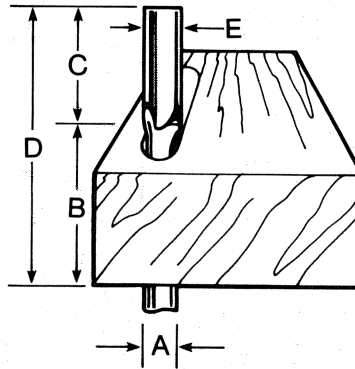

Stagger Tooth

Offers two flute balance with the cutting speed of a single flute, plus excellent chip clearance.

Straight Bits

Single Flute

High-Speed Steel

A Cut. Dia.	B Flute Lgth.	C Shank Lgth.	D Overall Lgth.	E Shank Dia.
1/16	5/32	1/4	1 13/32	1/4
3/32	3/16	1/4	1 7/16	1/4
1/8	3/8	1/4	1 5/8	1/4
1/8	1/2	1/4	1 3/4	1/4
5/32	1/2	1/4	1 3/4	1/4
3/16	3/8	1/4	1 7/8	1/4
3/16	3/4	1/4	2	1/4
7/32	3/8	1/4	1 7/8	1/4
1/4	1	1/4	2 1/4	1/4

Carbide-Tipped

A Cut. Dia.	B Flute Lgth.	C Shank Lgth.	D Overall Lgth.	E Shank Dia.
3/16	1/2	1 1/16	1 11/16	1/4
1/4	3/4	1	2	1/4
1/4	1	1	2 1/4	1/4
3/8	1	1	2 1/4	3/8
3/8	1	1 1/4	2 1/2	1/2
1/2	1 1/4	1 1/4	2 3/4	1/2
1/2	1 1/2	1 1/4	3	1/2
1/2	2	1 3/4	4	1/2

Two Flutes

High-Speed Steel

A Cut. Dia.	B Flute Lgth.	C Shank Lgth.	D Overall Lgth.	E Shank Dia.
1/4	5/8	1	1 5/8	1/4
1/4	1	1 1/4	2 1/4	1/4
5/16	3/4	1	1 3/4	1/4
3/8	3/4	1	1 3/4	1/4
3/8	1	1 1/4	2 1/4	1/4
1/2	3/4	1	1 3/4	1/4
5/8	3/4	1	1 3/4	1/4
3/4	3/4	1	1 3/4	1/4
1 1/4	1 1/32	1 11/32	1 11/16	1/4
3/8	1	1 1/2	2 1/2	1/2
1/2	1 1/4	1 1/2	2 3/4	1/2
1/2	1 1/2	1 1/2	3	1/2
5/8	1 1/4	1 1/2	2 3/4	1/2
3/4	1 1/4	1 1/2	2 3/4	1/2

Carbide-Tipped

A Cut. Dia.	B Flute Lgth.	C Shank Lgth.	D Overall Lgth.	E Shank Dia.
1/8	5/16	1	1 1/2	1/4
3/16	1/2	1	1 5/8	1/4
1/4	3/4	1	2	1/4
1/4	1	1	2 5/16	1/4
5/16	1	1 1/16	2 1/4	1/4
3/8	1	1 1/16	2 1/4	1/4
1/2	1	1 1/16	2 5/16	1/4
5/8	3/4	1 1/16	2 1/16	1/4
3/4	3/4	1 1/16	2 1/16	1/4
1/4	3/4	1	2 1/8	3/8
3/8	1	1	2 1/4	3/8
3/8	1 1/4	2	3 3/8	3/8
1/2	1	1	2 3/8	3/8
5/8	3/4	1 1/16	2	3/8
3/4	3/4	1 1/16	2	3/8
5/16	3/4	1 1/4	2 1/4	1/2
3/8	1	1 1/4	2 1/2	1/2
7/16	1 1/4	1 1/4	2 3/4	1/2
1/2	1	1 1/4	2 1/2	1/2
1/2	1 1/4	1 1/4	2 3/4	1/2
1/2	1 1/2	1 1/4	3	1/2
1/2	2	1 3/4	4	1/2
3/4	1 1/4	1 1/4	2 7/8	1/2
1	1 1/4	1 1/4	2 7/8	1/2

Stagger Tooth

Carbide-Tipped

A Cut. Dia.	B Flute Lgth.	C Shank Lgth.	D Overall Lgth.	E Shank Dia.
3/8	1 3/8	1 1/8	2 3/4	3/8
3/8	1 3/8	1 1/4	2 7/8	1/2
1/2	1 1/2	1 1/8	3 1/4	1/2
1/2	2	1 1/2	4	1/2
5/8	2	2 1/4	4 1/2	1/2

Grooving Bits

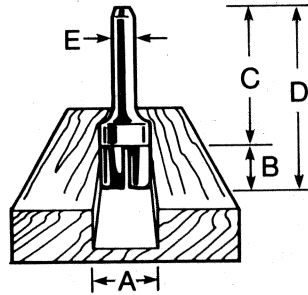

Hinge Mortising

Fast, clean cutting of hinge butt mortises with all makes of doorhanging templates.

High-Speed Steel

A Cut. Dia.	B Flute Lgth.	C Shank Lgth.	D Overall Lgth.	E Shank Dia.
1/2	1/2	1 1/4	2	1/4
5/8	1/2	1 1/4	2	1/4

Carbide-Tipped

A Cut. Dia.	B Flute Lgth.	C Shank Lgth.	D Overall Lgth.	E Shank Dia.
1/2	5/8	1 1/2	1 7/8	1/4
5/8	5/8	1 1/2	1 7/8	1/4
3/4	3/4	1 1/2	2 1/4	1/4
1 1/4	1/2	1 1/2	2	1/4

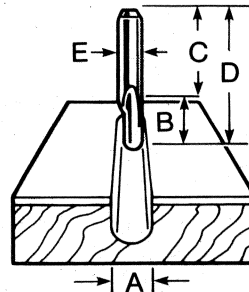

Veining

Excellent for decorative freehand routing, carving, and inlay work.

Veining

High-Speed Steel

A Cut. Dia.	B Flute Lgth.	C Shank Lgth.	D Overall Lgth.	E Shank Dia.
1/16	3/16	1	1 3/16	1/4
3/32	3/16	1	1 3/16	1/4
1/8	5/16	1	1 5/16	1/4
3/16	7/16	1	1 7/16	1/4
7/32	7/16	1	1 7/16	1/4

Solid Carbide

A Cut. Dia.	B Flute Lgth.	C Shank Lgth.	D Overall Lgth.	E Shank Dia.
1/8	1/4	1 1/4	1 1/2	1/4
3/16	1/4	1 1/4	1 1/2	1/4
1/4	1/4	1 1/4	1 1/2	1/4

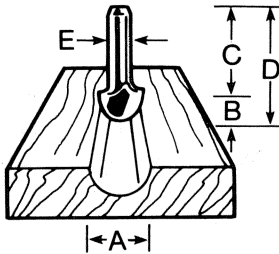

Core Box

Especially effective in reeding, fluting, letter cutting, and general ornamentation.

High-Speed Steel

r Rad.	A Cut. Dia.	B Cut Lgth.	C Shank Lgth.	D Over- all Lgth.	E Shank Dia.
1/8	1/4	1/4	1	1 1/4	1/4
3/16	3/8	1/4	1	1 1/4	1/4
1/4	1/2	1 1/32	1	1 1 1/32	1/4
5/16	5/8	3/8	1	1 3/8	1/4
3/8	3/4	15/32	1	1 15/32	1/4

Carbide-Tipped

r Rad.	A Cut. Dia.	B Cut Lgth.	C Shank Lgth.	D Over- all Lgth.	E Shank Dia.
1/8	1/4	5/32	1	1 1/4	1/4
3/16	3/8	1/4	1	1 3/8	1/4
1/4	1/2	3/8	1	1 1/2	1/4
5/16	5/8	7/16	1	1 1/2	1/4
3/8	3/4	1/2	1	1 1/2	1/4

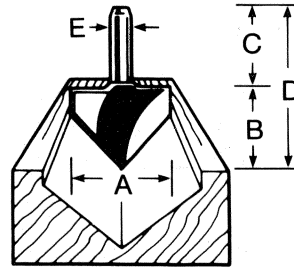

"V" Grooving

Ideal for smooth "V" cuts in paneling, lettering and signs, edge mitering, and general decorative work.

High-Speed Steel

A Cut. Dia.	B Depth of Cut	C Shank Lgth.	D Overall Lgth.	E Shank Dia.
3/8	7/16	1	1 7/16	1/4
7/8	15/16	1	1 15/16	1/4

Carbide-Tipped

A Cut. Dia.	B Depth of Cut	C Shank Lgth.	D Overall Lgth.	E Shank Dia.
1/4	5/32	1 5/8	2	1/4
3/8	1/4	1	1 11/16	1/4
3/4	3/8	1 1/2	2 7/8	1/2
1	1/2	1 1/2	2 7/8	1/2

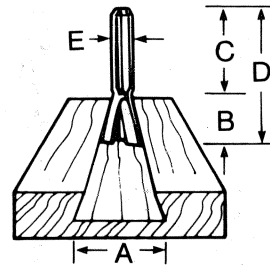

Dovetail

Excellent for cutting dovetail joints in wood, composition board, plywood, and laminates.

High-Speed Steel

A Cut. Dia.	B Depth of Cut	C Shank Lgth.	D Overall Lgth.	E Shank Dia.
1/4	3/8	1 1/4	1 5/8	1/4
1/2	1 7/32	1 1/16	1 19/32	1/4

Carbide-Tipped

A Large Dia.	Degree Ea. Side	B Depth of Cut	C Shank Lgth.	D Over- all Lgth.	E Shank Dia.
3/8	9° 18'	3/8	1	1 7/16	1/4
1/2	14°	1/2	1 1/16	1 9/16	1/4

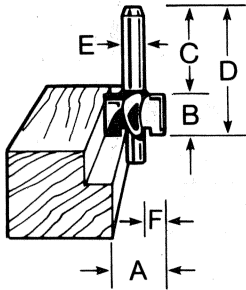

Rabbeting

For smooth, fast rabbeting, and step cutting of edges without a router guide.

High-Speed Steel with self-guiding pilot.

A Large Dia.	B Cut. Lgth.	C Shank Lgth.	D Over- all Lgth.	E Shank Dia.	F Depth of Rab.
3/4	7/16	1	1 1/16	1/4	1/4
1	9/16	1	1 3/16	1/4	3/8

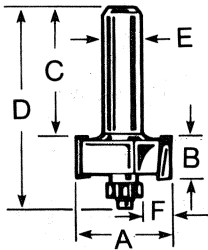

Carbide Tipped with ball bearing guide.

A Large Dia.	B Cut. Lgth.	C Shank Lgth.	D Over- all Lgth.	E Shank Dia.	F Depth of Rab.
1 1/4	1/2	1 1/2	2 1/4	1/4	3/8

Decorating Bits

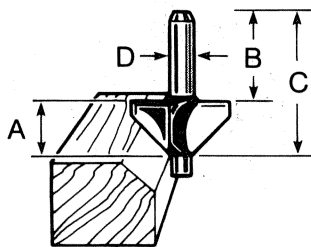

Chamfering

Excellent for 45° edge cuts and 45° mitered panel joints. High shear angle clears chips fast for chatter-free cut.

High-Speed Steel holds its sharp edge.

A Depth of Cut.	B Shank Lgth.	C Overall Lgth.	D Shank Dia.
9/16	1	1 13/16	1/4

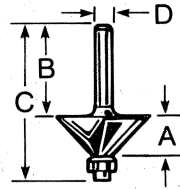

Carbide-Tipped with ball bearing guide.

A Depth of Cut.	B Shank Lgth.	C Overall Lgth.	D Shank Dia.
7/16	1	1 9/16	1/4

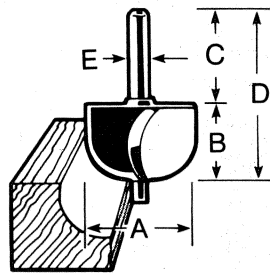

Cove

Router bit pilot eliminates need for supplemental fences, templates, and guides in decorative edging.

High-Speed Steel.

r Rad.	A Large Dia.	B Cut. Lgth.	C Shank Lgth.	D Over- all Lgth.	E Shank Dia.
3/16	1/2	1/2	1	1 3/4	1/4
1/4	5/8	1/2	1	1 3/4	1/4
3/8	7/8	3/4	1	2	1/4
1/2	1 1/8	3/4	1	2	1/4

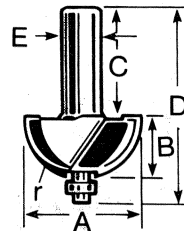

Carbide-Tipped with ball bearing guide.

r Rad.	A Large Dia.	B Cut. Lgth.	C Shank Lgth.	D Over- all Lgth.	E Shank Dia.
1/4	7/8	1/2	1	1 1/2	1/4
3/8	1 1/8	1/2	1	1 3/4	1/4
1/2	1 3/8	5/8	1	1 3/4	1/4

Decorating Bits (Cont'd)

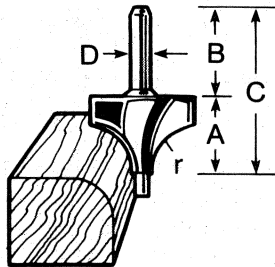

Corner Rounding

For decorative edging and smooth, uniform rounding of sharp edges.

High-Speed Steel minimizes resharpenering.

r Rad.	A Depth of Cut	B Shank Lgth.	C Overall Lgth.	D Shank Dia.
3/16	3/8	1	1 5/8	1/4
1/4	1/2	1	1 3/4	1/4
5/16	1/2	1	1 3/4	1/4
3/8	5/8	1	1 7/8	1/4
1/2	13/16	1	2 1/16	1/4

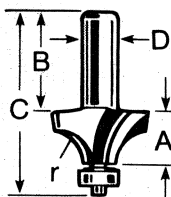

Carbide-Tipped with mar-free ball bearing pilot.

r Rad.	A Depth of Cut	B Shank Lgth.	C Overall Lgth.	D Shank Dia.
1/4	1/2	1 1/4	1 3/4	1/4
3/8	5/8	1 3/8	2	1/4
1/2	3/4	1 1/4	2	1/4

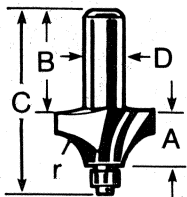

Beading

A basic woodworking bit for rounding corners and cutting small edge beads cleanly.

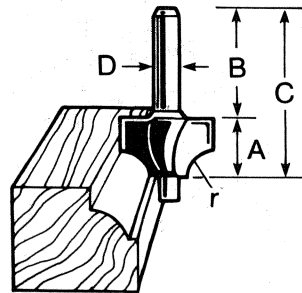

High-Speed Steel

r Rad.	A Depth of Cut	B Shank Lgth.	C Overall Lgth.	D Shank Dia.
1/8	3/8	1	1 5/8	1/4
1/4	1/2	1	1 3/4	1/4
3/8	3/4	1	2	1/4
1/2	3/4	1	2	1/4

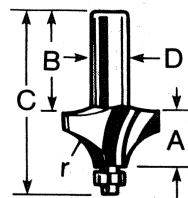

Carbide-Tipped (Ball Bearing Guide)

r Rad.	A Depth of Cut	B Shank Lgth.	C Overall Lgth.	D Shank Dia.
3/16	1/2	1 1/4	1 3/4	1/4
1/4	1/2	1 1/4	1 3/4	1/4
3/8	5/8	1 3/8	2	1/4
1/2	3/4	1 1/4	2	1/4

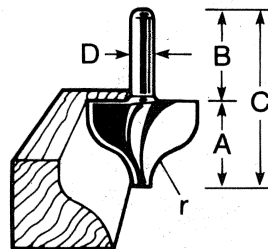

Ogee

For attractive, eye-catching grooving and edge-forming cuts. Use with a template or straight edge guide.

High-Speed Steel

r Rad.	A Depth Cut	B Shank Lgth.	C Overall Lgth.	D Shank Dia.
3/16	5/8	1	1 5/8	1/4
9/32	29/32	1	1 29/32	1/4

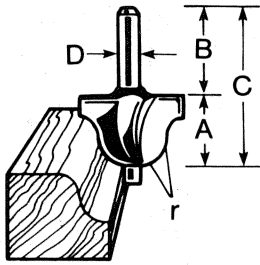

Roman Ogee

For producing decorative edges and cuts on period furniture.

High-Speed Steel

r Rad.	A Depth of Cut	B Shank Lgth.	C Overall Lgth.	D Shank Dia.
$\frac{5}{32}$	$\frac{1}{2}$	1	$1\frac{3}{4}$	$\frac{1}{4}$
$\frac{1}{4}$	$\frac{3}{4}$	1	2	$\frac{1}{4}$

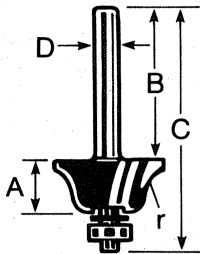

Carbide-Tipped (Ball Bearing Pilot)

r Rad.	A Depth of Cut	B Shank Lgth.	C Overall Lgth.	D Shank Dia.
$\frac{5}{32}$	$\frac{15}{32}$	$1\frac{1}{4}$	$2\frac{1}{4}$	$\frac{1}{4}$
$\frac{1}{4}$	$\frac{15}{32}$	$1\frac{1}{4}$	$2\frac{3}{8}$	$\frac{1}{4}$

Laminate Trimming Bits, Solid Carbide

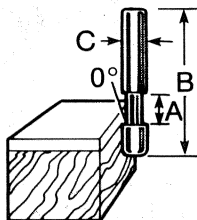

Flush Trimming

Makes flush square corners and small, intricate cuts on laminated plastics.

Type of Cut	A Cut. Edge	B Overall Lgth.	C Shank Dia.
Flush 0°	$\frac{5}{16}$	$1\frac{1}{2}$	$\frac{1}{4}$

Laminate Trimming Assemblies and Replacement Bits

Trim Tool Assemblies

Chatter-free trimming at high speeds.

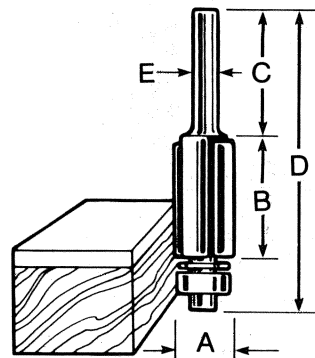

Two Flute, Carbide Tipped. Complete with high-speed, ballbearing guide and dust-slinger shield.

A Cut. Dia.	B Cut. Lgth.	C Shank Lgth.	D Overall Lgth.	E Shank Dia.
$\frac{3}{8}$	$\frac{1}{2}$	1	$2\frac{1}{4}$	$\frac{1}{4}$
$\frac{3}{8}$	1	1	$2\frac{3}{4}$	$\frac{1}{4}$
$\frac{1}{2}$	$\frac{1}{2}$	1	$2\frac{1}{4}$	$\frac{1}{4}$
$\frac{1}{2}$	1	1	$2\frac{3}{4}$	$\frac{1}{4}$
$\frac{1}{2}$	1	1	$3\frac{1}{4}$	$\frac{1}{2}$
25° bevel	$\frac{9}{32}$	$1\frac{1}{8}$	2	$\frac{1}{4}$

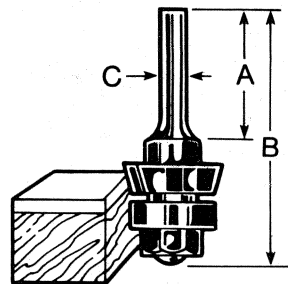

Four Flute, Carbide Tipped. Completely assembled with arbor, cutter, and high-speed shielded ball-bearing guide.

Type Cut	A Shank Lgth.	B Overall Lgth.	C Shank Dia.
flush	1	$2\frac{3}{8}$	$\frac{1}{4}$
15°	1	$2\frac{3}{8}$	$\frac{1}{4}$
25°	1	$2\frac{3}{8}$	$\frac{1}{4}$

Bevel Trimmer

Puts a 7° bevel on finished edge of laminated plastic used to face cabinets, furniture, doors.

Type of Cut	A Cut. Edge	B Overall Lgth.	C Shank Dia.
7°	5/16	1½	¼

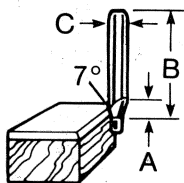

Hole and Flush Trim

Drills its own hole and trims laminated plastic, leaving a clean, sharp, flush edge.

Type of Cut	A Cut. Edge	B Overall Lgth.	C Shank Dia.
Drill Flush	3/8	1½	¼

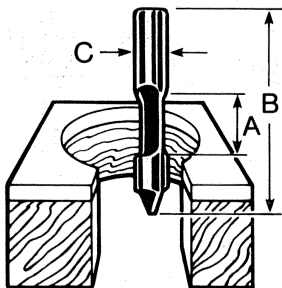

Rip and Slotting

For chip-free ripping and slotting of laminated plastics, non-ferrous metals, woods, and plastics.

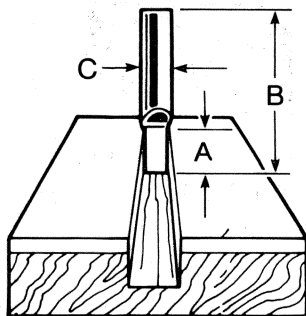

Type of Cut	A Cut. Edge	B Overall Lgth.	C Shank Dia.
Cut Off Slot	3/8	1½	¼

Trimming Bits for Aluminum

Spiral flute, high-speed steel, shear-cut bits for trimming and cutting aluminum, non-ferrous metals, some plastics, and some woods.

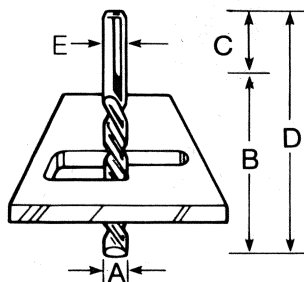

Down Spiral

Recommended for shallow inlay slotting to minimize chipping.

A Cut. Dia.	B Flute Lgth.	C Shank Lgth.	D Overall Lgth.	E Shank Dia.
1/8	3/8	1 1/8	2 1/4	1/4
1/4	1	1 3/4	2 3/4	1/4

Up Spiral

Recommended for deep slotting to remove chips from the cut.

A Cut. Dia.	B Flute Lgth.	C Shank Lgth.	D Overall Lgth.	E Shank Dia.
1/8	3/8	1 1/8	2 1/4	1/4
1/4	1	1 3/4	2 3/4	1/4
3/8	1	1 3/4	2 3/4	3/8

Flush and Bevel Trim Bits for Laminate Trimmers

Carbide tipped. Made to manufacturer's specifications. Designed for use with Black & Decker, Stanley, and Millers Falls laminate trimmers.

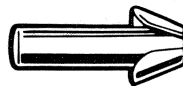

Combination flush and 22° bevel, 5/16" dia., 1/4" shank



22° bevel, 5/16" dia., 1/4" shank

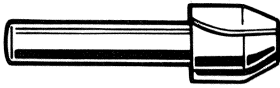

Combination flush and 22° bevel, 7/16" dia., 1/4" shank

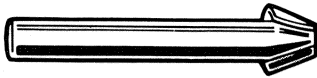

22° bevel, 7/16" dia., 1/4" shank

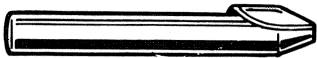

Combination flush and 22° bevel, 1/4" shank

Panel Pilot Bits with Drill Point

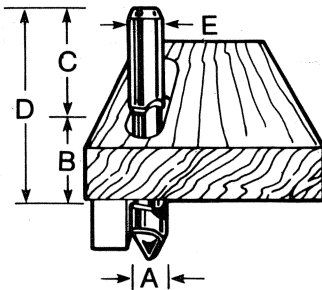

Fast fast cutting of openings to exact dimensions through covering materials.

High-Speed Steel

A Cut. Dia.	B Flute Lgth.	C Shank Lgth.	D Overall Lgth.	E Shank Dia.
1/4	3/4	1 5/16	2 5/16	1/4
3/8	7/8	1 1/8	2 1/4	3/8
1/2	1	1 1/8	2 3/8	1/2
3/8	1	1 1/8	2 3/8	3/8

Carbide-Tipped Single Flute

A Cut. Dia.	B Flute Lgth.	C Shank Lgth.	D Overall Lgth.	E Shank Dia.
1/4	7/8	1	2 1/2	1/4
3/8	1	1 1/8	3	3/8
3/8	1 5/16	1 7/16	3	1/2
1/2	1 1/4	1 1/4	3 1/2	1/2
1/2	2	2	4 1/2	1/2

Two Flute

3/8	1	1	2 7/8	1/4
3/8	1	1	2 7/8	3/8
1/2	1 1/4	1	3 3/8	1/2

Slotting Cutters

Carbide Tipped. For weatherstrip and trim strip applications, and for kerfing wood and composition boards.

Arbor Hole: 5/16"

Cutter Diameter: 1 7/8"

A Kerf Width	B Depth of Cut	Diameter	
		C Total	D Shank
1/16	1/2	1 7/8	1/4
5/64			
3/32			
1/4	9/32	1 3/16	1/4

Slotting Cutters

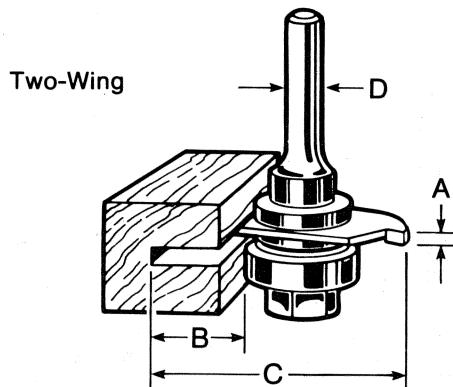

Two-Wing Assemblies

A Kerf Width	B Depth of Cut	Diameter	
		C Total	D Shank
1/16	1/2	1 7/8	1/4
5/64			
3/32			
1/8			
1/4			

Two-Wing, Carbide-Tipped Replacement Cutters

A Kerf Width	B Depth of Cut	Diameter	
		C Total	D Shank
1/16	1/2	1 7/8	1/4
5/64			
3/32			
1/8			
1/4			

Slotting Cutters

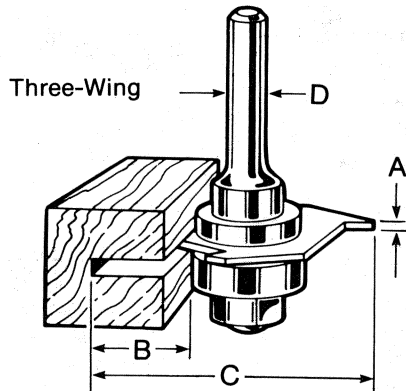

Three-Wing Assemblies

A Kerf Width	B Depth of Cut	Diameter	
		C Total	D Shank
1/16	1/2	1 1/8	1/4
5/64			
3/32			
1/8			
1/4			

Three-Wing, Carbide-Tipped Replacement Cutters

A Kerf Width	B Depth of Cut	Diameter	
		C Total	D Shank
1/16	1/2	1 1/8	1/4
5/64			
3/32			
1/8			
1/4			

Straight Edge Guide Cat. No. 63977

The straight edge guide provides an accurate guide fence for routing along the edge of straight pieces of stock. Lock screws in the sub-base must be tightened after desired setting is made. Mounting holes have been provided for addition of edge guide extensions where required.

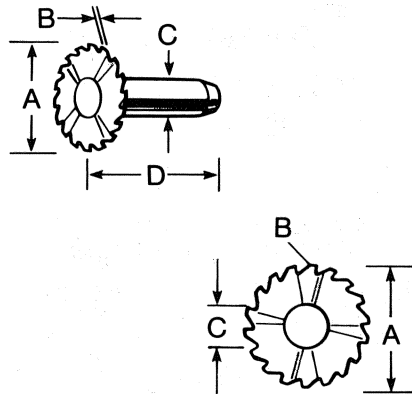
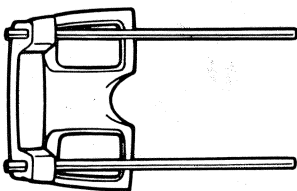

Trimming Saw

Solid Carbide. Designed for the professional applicators.

Assembly

A Blade Dia.	B Kerf Width	C Shank Dia.	D Shank Length
3/4	1/32	1/4	1

Saw Blade, Solid Carbide

A Blade Dia.	B Kerf Width	C Shank Dia.
3/4	1/32	1/4

Replacement Parts

Arbors

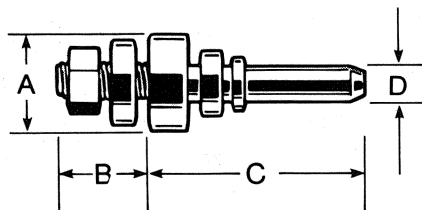

A Overall Dia.	B Arbor Lgth.	C Shank Lgth.	D Shank Dia.	Thread
5/8	7/8	1 1/4	1/4	1/4-24
1/2	7/8	1	1/4	5/16-24
1/2	7/8	1	3/8	5/16-24
1/2	7/8	1	1/2	5/16-24

Bearings

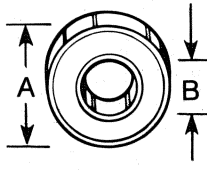

A Outside Dia.	B Inside Dia.
$13/16$	$1/4$
$3/8$	$3/16$
$3/8$	$1/8$
$1/2$	$3/16$
$7/8$	$5/16$
$5/8$	$1/4$

Carbide-Tipped Trim Cutters

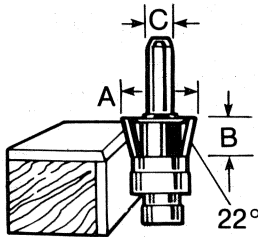

A	B	C
22° Bevel Trimming Cutter • Carbide-Tipped		
$57/64$	$3/8$	$1/4$
45° Bevel Trimming Cutter • Carbide-Tipped		
1	$1/4$	$1/4$
Flush Trimming Cutter • Carbide-Tipped		
$5/8$	$3/8$	$1/4$

Collets

Collet-type chucks are also available in $1/4$ " size, Cat. No. 62132 and $3/8$ " size, Cat. No. 64119 to accommodate all shank sizes of the wide range of Black & Decker bits and cutters.

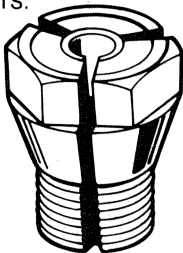

The accessories listed in this manual are available at extra cost from your local dealer or Black & Decker Service Center. A complete listing of service centers is included on the owner's registration card packed with your tool.

If you need assistance in locating any accessory, please contact: Black & Decker (U.S.) Inc., Consumer Service Department, 626 Hanover Pike, P.O. Box 618, Hampstead, MD 21074-0618.

CAUTION: ONLY THE ACCESSORIES SHOWN IN THIS MANUAL ARE RECOMMENDED FOR USE WITH YOUR ROUTER.

THE USE OF ANY OTHER ACCESSORY OR ATTACHMENT MIGHT BE HAZARDOUS.

Template Guides

Template routing is the fastest and most accurate method of duplicating intricate designs. Black & Decker's complete new line of template guides from $5/16$ " to $1 3/8$ " permits a wide selection of Router applications where templates are required for precise, duplicate cutting.

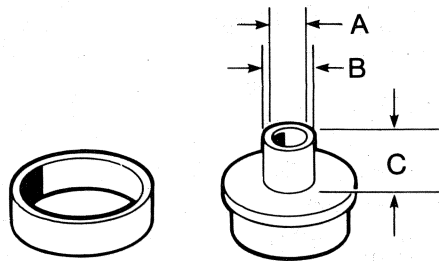

CAT. NO.	A IN.	B IN.	C IN.
1) C62943	$17/64$	$5/16$	$3/16$
C62944	$9/32$	$3/8$	$3/16$
2) C62945	$11/32$	$7/16$	$3/16$
C62946	$13/32$	$1/2$	$3/8$
3) C62947	$17/32$	$39/64$	$5/8$
C62949	$5/8$	$13/16$	$9/16$
C62950	$27/32$	1	$7/16$
4) C62951	$1 19/64$	$1 3/8$	$1/2$
C62942			

*Template guide nut fits all of above guides.
Please order separately.*

- 1) For use with $1/4$ " dovetail template.
- 2) For use with $1/2$ " dovetail template.
- 3) For use with hinge mortising template.
- 4) For use with $5/8$ " radius hinges.

Extension Cords

Tools that have 3 wire cords requiring grounding must only be used with extension cords that have 3-prong grounding type plugs and 3-pole receptacles. Only round jacketed extension cords should be used, and we recommend that they be listed by Underwriters Laboratories (U.L.) (C.S.A. in Canada). If the extension will be used outside, the cord must be suitable for outdoor use. Any cord marked as outdoor can also be used for indoor work.

An extension cord must have adequate wire size (AWG or American Wire Gauge) for safety, and to prevent loss of power and overheating. The smaller the gauge number of the wire, the greater the capacity of the cable, that is 16 gauge has more capacity than 18 gauge. When using more than one extension cord to make up the total length, be sure each individual extension contains at least the minimum wire size.

To determine the minimum wire size required, refer to the chart below:

CHART FOR MINIMUM WIRE SIZE (AWG) OF EXTENSION CORDS								
NAMEPLATE RATING - AMPS	TOTAL EXTENSION CORD LENGTH - FEET							
	25	50	75	100	125	150	175	200
0 - 10.0	18	18	16	16	14	14	12	12
10.1 - 13.0	16	16	14	14	14	12	12	12
13.1 - 15.0	14	14	12	12	12	12	12	--

Before using an extension cord, inspect it for loose or exposed wires, damaged insulation, and defective fittings. Make any needed repairs or replace the cord if necessary.

Commercial/Industrial Use Warranty

Elu warrants this product for one year from date of purchase. We will repair without charge, any defects due to faulty material or workmanship. Please return the complete unit, transportation prepaid, to any Black & Decker Service Center or Authorized Service Station listed under "Tools Electric" in the yellow pages. This warranty does not apply to accessories or damage caused where repairs have been made or attempted by others.

Every Elu tool is of the highest quality. If you wish to contact us regarding this product, please call toll free between 8:00 a.m. and 5:00 p.m. ET Monday through Friday. 1-800-762-6672

Important

To assure product SAFETY and RELIABILITY, repairs, maintenance and adjustment (including brush inspection & replacement) should be performed by BLACK & DECKER Service Centers or other qualified service organizations, always using BLACK & DECKER replacement parts.

Like most Elu tools, your Router is listed by Underwriters' Laboratories to ensure that it meets stringent safety requirements.

This symbol on the nameplate means the product is Listed by Underwriters' Laboratories, Inc.



See 'Tools-Electric'
—Yellow Pages—
for Service & Sales



BLACK & DECKER (U.S.) INC., U.S. Power Tools Group, 701 E. Joppa Rd., Towson, MD 21286 U.S.A.

Form No. 741974-01
COPYRIGHT ©1992 Black & Decker
(NOV92-CD-1)
Printed in U.S.A.